

PARTS LIST  
WITH RECOMMENDED SPARE

**LP-12 SERIES PUMP**



MODEL

**LP - 12**

Thomas Pump & Machinery  
120 Industrial Drive  
Slidell, LA 70460

PH: 985-649-3000  
Fax: 985-649-4300

# SECTION DRAWING

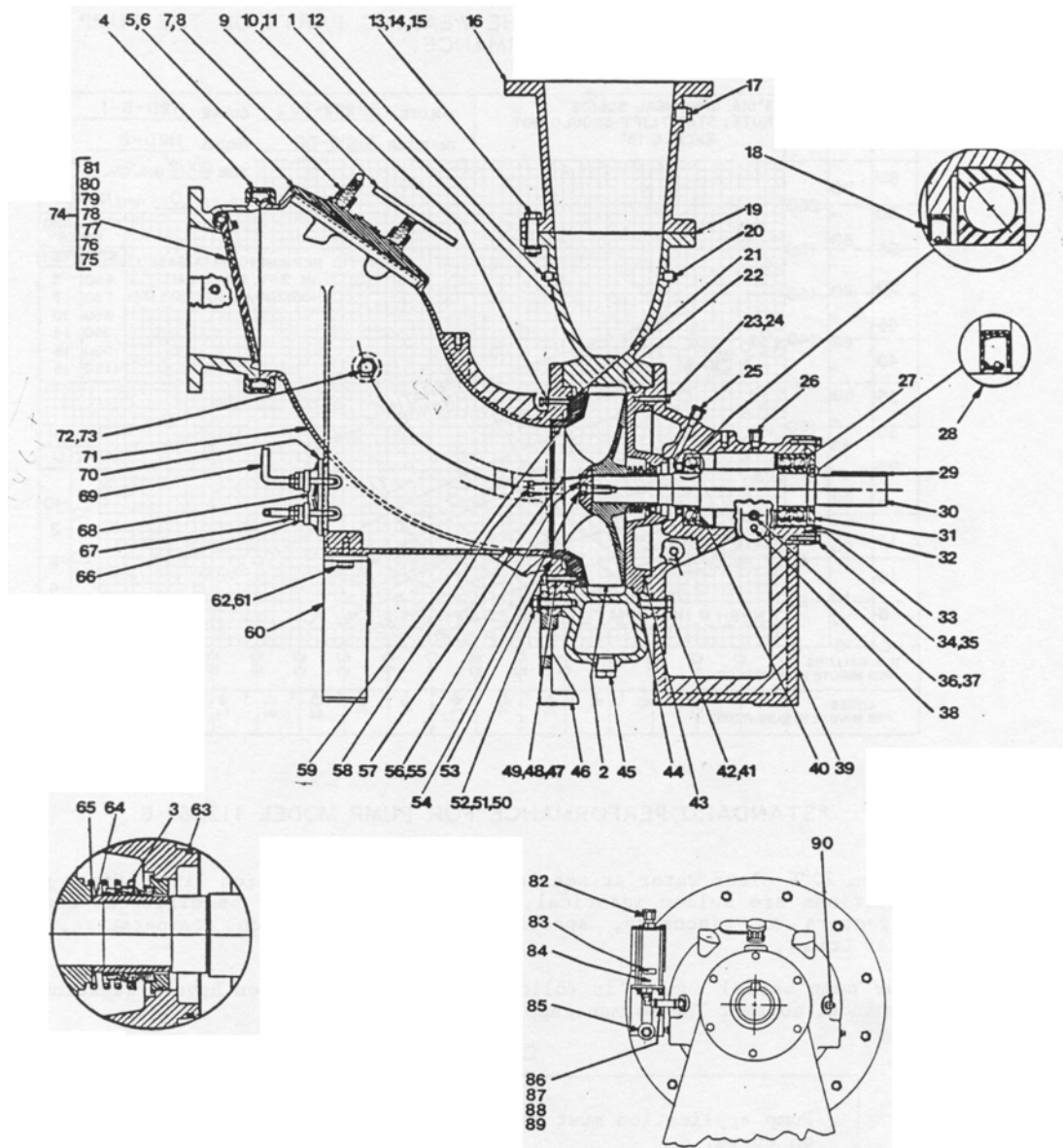

**PARTS LIST**  
**Pump Model LP-12**

ITEM NO.		PART NAME	QTY	PART NUMBER
01		<b>PUMP CASING</b>	<b>01</b>	<b>9600154000</b>
02	*	IMPELLER	01	9600497000
03	*	<b>SEAL ASSY</b>	<b>01</b>	<b>9800911000</b>
04	*	VICTAULIC CPLG	01	9700777000
05		<b>ACCESS COVER ASSY</b>	<b>01</b>	<b>9700498000</b>
06	*	COVER GSTK	01	9901378000
07		<b>COVER CLAMP</b>	<b>02</b>	<b>9901379000</b>
08		MACHINE BOLT	04	2102565120
09		<b>CLAMP BAR SCREW</b>	<b>02</b>	<b>9901380000</b>
10	*	WEAR PLT ADJ SCREW	04	9901381000
11	*	<b>WEAR PLT JAM NUT</b>	<b>04</b>	<b>2211270050</b>
12		PIPE PLUG	01	3310271020
13		<b>HEX HD CAPSCREW</b>	<b>12</b>	<b>2101266480</b>
14		LOCKWASHER	12	2321081540
15		<b>HEX NUT</b>	<b>12</b>	<b>2211270090</b>
16		DISCH ADAPTOR	01	9700499000
17		<b>ACCESSORY PLUG</b>	<b>01</b>	<b>3310271100</b>
18	*	OIL SEAL	01	3680080350
19	*	<b>DISCH FLANGE GSKT</b>	<b>01</b>	<b>9901382000</b>
20		PIPE PLUG	01	3310271060
21	*	<b>WEAR PLT O-RING</b>	<b>01</b>	<b>3606630050</b>
22	*	CASING O-RING	01	3606222840
23		<b>HEX HD CAPSCREW</b>	<b>02</b>	<b>2101262630</b>
24		LOCKWASHER	02	2321080800
25	*	<b>SEAL CAVITY VENT</b>	<b>01</b>	<b>3310990060</b>
26	*	PEDESTAL VENT	01	3310990060
27	*	<b>WAVE WASHER</b>	<b>02</b>	<b>9901384000</b>
28	*	OIL SEAL	01	3680080340
29	*	<b>SHAFT KEY</b>	<b>01</b>	<b>9901383000</b>
30	*	IMP SHAFT	01	9800914000
31		<b>BEARING CAP</b>	<b>01</b>	<b>9901385000</b>
32	*	BALL BEARING	01	3180590085
33	*	<b>BRG CAP O-RING</b>	<b>01</b>	<b>3606127530</b>
34		HEX HD CAPSCREW	06	2101263910
35		<b>LOCKWASHER</b>	<b>06</b>	<b>2321080840</b>
36		OIL SIGHT GAUGE	01	3480500200
37		<b>PIPE PLUG</b>	<b>01</b>	<b>3310271040</b>
38		PED DRAIN PLUG	01	3310271040
39		<b>BEARING HOUSE</b>	<b>01</b>	<b>9700501000</b>
40	*	BALL BEARING	01	3180071870
41		<b>HEX HD CAPSCREW</b>	<b>20</b>	<b>2101132290</b>
42		LOCKWASHER	20	2321080920
43	*	<b>PEDESTAL O-RING</b>	<b>01</b>	<b>3606222840</b>
44		SEAL PLATE	01	9700502000
45		<b>CASING DRAIN PLUG</b>	<b>01</b>	<b>3310271140</b>
46		PEDESTAL FOOT	01	9800415000
47		<b>STUD</b>	<b>04</b>	<b>2101263940</b>
48		LOCKWASHER	04	2320080840
49		<b>HEX NUT</b>	<b>04</b>	<b>2211270050</b>
50		STUD	04	9901386000

\* INDICATES PARTS RECOMMENDED FOR STOCK

ITEM NO.		PART NAME	QTY	PART NUMBER
51		LOCKWASHER	04	2321080920
52		HEX NUT	04	2211270080
53	*	WEAR PL O-RING	01	3606131360
54	*	SCKT HD CAPSCREW	01	2102185810
55	*	IMPELLER WASHER	01	9901387000
56	*	IMP ROLL PIN	01	2431101410
57	*	IMPELLER KEY	01	9901389000
58		HEX HD CAPSCREW	02	2101265850
59	*	WEAR PLATE	01	9700503000
60		SUCTION ELBOW	01	9901817000
61		HEX HD CAPSCREW	02	2101255810
62		LOCKWASHER	02	2321080920
63	*	SEAL PLT O-RING	01	3606125570
64	*	SHAFT SLEEVE	01	9902130000
65	*	IMP SCREW SET	01	2322150010
66		COVER PLT CLAMP	02	9901388000
67		MACHINE BOLT	04	2102565120
68		CLEANOUT CVR ASSY	01	9800916000
69		CLAMP BAR SCREW	02	9901311000
70	*	COVER GSKT	01	9901390000
71		SUCTION ELBOW	01	9600155000
72	*	PRES RELIEF VLV	01	3768500300
73		PIPE PLUG	01	3310271060
74		CHECK VALVE ASSY	01	-
75		HEX HD CAPSCREW	02	2101302590
76		PIPE PLUG	02	3310271060
77		FLAT WASHER	04	2320290800
78		PIVOT CAP	02	9901356000
79		CHECK VLV BODY	01	9700504000
80		LOCKWASHER	02	2321110800
81	*	CHECK VALVE	01	9700461000
82		AIR VENT	01	2890090960
83		OIL LEVEL DECAL	01	9901842000
84		SIGHT GAUGE ASSY	01	9801497000
85		FLAT WASHER	02	2321013800
86		BARBED ELBOW	01	3319321040
87		BARBED ADAPTOR	01	2890090940
88		PLASTIC TUBING	01	2890090950
89		TUBING CLAMP	02	2890090930
90		SEAL DRAINING PLUG	03	3310241040

\* INDICATES PARTS RECOMMENDED FOR STOCK